

MODELS
CNE1430
CNY1250

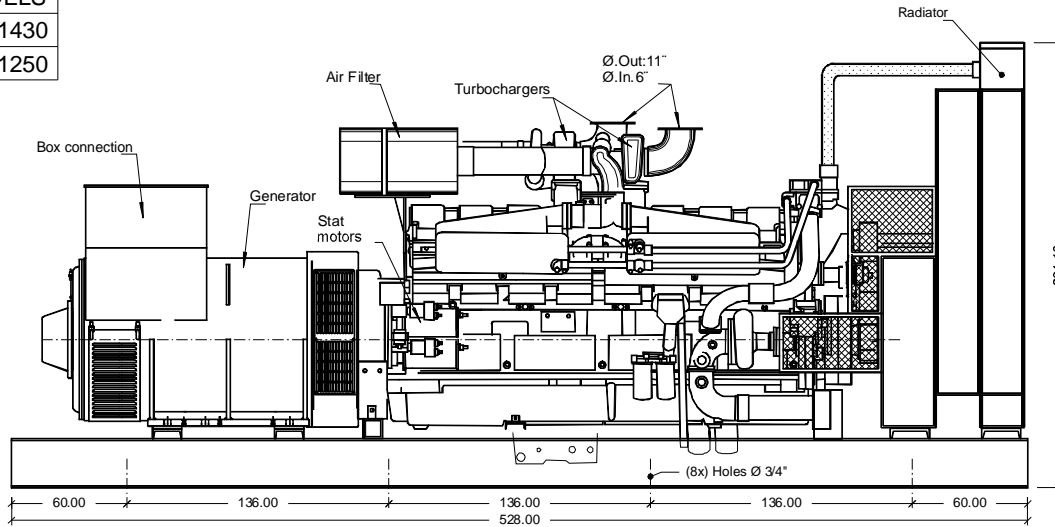

SIDE VIEW

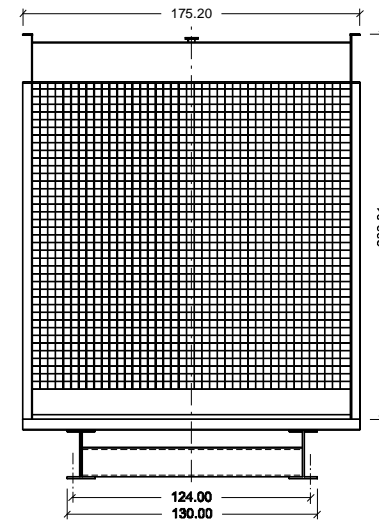

FRONT VIEW

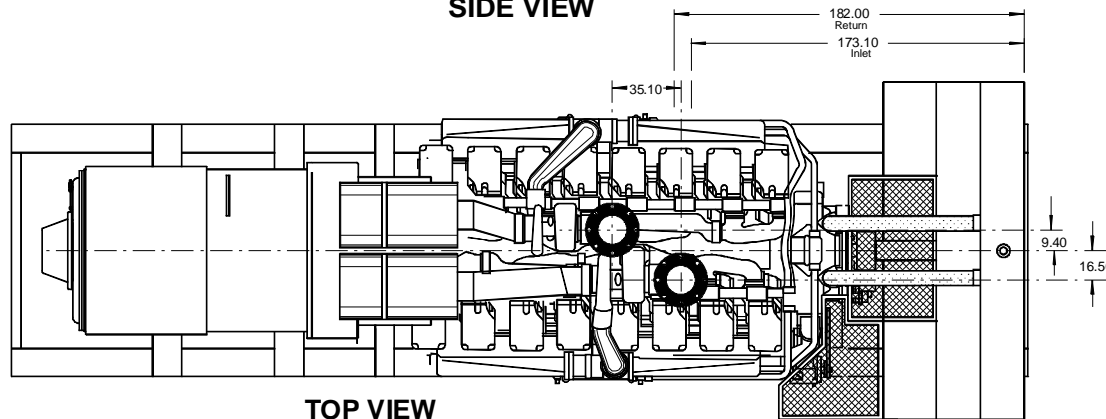

TOP VIEW

DESCRIPTION	
RADIATOR:	55705
ENGINE:	KTA 50 G3
AIR FILTER:	AH1135 (2X)
BASE FRAME:	BP-KTA50G3-STF
# SPRING AVMS:	8 PZS

-THE GENSET DIMENSIONS ARE THE SAME BY FAMILY MODEL, THERE COULD BE ONLY DIFFERENCES ON THE ALTERNATOR LENGTH SEE SPECIFIC GENERAL ARRANGEMENT DRAWING OF CERTAIN MODEL
-TOTAL WEIGHT COULD VARY CHECK RATING CHART FOR EACH MODEL

Customer: _____ S/O: _____

Rev.	Description	Date	Certificated

Title: CUMMINS ENGINE KTA50G3 - STAMFORD ALTERNATOR			
Draw: R.G.C.	Revised: F.H.M.	Certificated: F.H.M.	Code: CNEY-16
Date: JAN 05th 2005	Date: JAN 05th 2005	Date: JAN 05th 2005	Dept.: Engineering
			Marks: oms Scale: s/e Draw: _____ DT: _____
Otomotores keeps the right to change the information with out prior notice			

Reviews